

PREMIUM TRUCK SCISSOR DOCK LIFT - WL-100-8-68

ANY ADDITIONS, DELETIONS, OR OMISSIONS MUST BE CORRECTED ON THIS DRAWING AS THIS DRAWING WILL BE CONSIDERED ALL INCLUSIVE
 ALL GRAPHICS PROVIDED ARE FOR REFERENCE ONLY. IF CERTAIN DIMENSIONS ARE CRITICAL PLEASE VERIFY THOSE DIMENSIONS WITH YOUR SALESPERSON

STANDARD FEATURES

MODEL NUMBER: WL-100-8-68
 UNIT TO BE MOUNTED: AT SURFACE OR IN PIT (CIRCLE ONE)
 CAPACITY (EVENLY DISTRIBUTED): 8,000 LBS
 OVERALL PLATFORM SIZE: (72" X 96")
 RAISED HEIGHT 70" ± 2"
 LOWERED HEIGHT: 10"
 REMOVABLE HANDRAILS AND 4" NON-REMOVABLE TOE BOARDS 42" HT W/ 21" MIDRAIL
 TRUCK BRIDGE IS 72" W X 18" L AT ROLLER END W/ CHAINS & HANDLES
 FRAME SIZE IS: 62" W X 93" L
 SHIPPING WT APPROX: 3500 LBS ±
 6 1/2 HP EXTERNAL POWER UNIT (SEE BOTTOM OF PAGE)
 W/ 8' OF HYDRAULIC HOSE
 -CONTROL IS HANDHELD, 2 BUTTON, NEMA 4 PENDANT WITH 4'-20' USABLE COIL CORD
 REFER TO THE UNIT'S ELECTRICAL DIAGRAM FOR ELECTRICAL SERVICE REQUIREMENTS
 -INSTALL TO MEET ALL APPLICABLE STATE & LOCAL CODES FOR YOUR AREA!
 5" BEVELED TOE GUARD
 ARCHITECTURAL REVIEW FOR CORRECTNESS OF PIT AND FOR COMPLIANCE TO LOCAL AND STATE CODES IS RECOMMENDED.
 UNIT IS DURABLE LIQUID PAINT BROWN FINISH
 HANDRAILS ARE TOUGH BAKED IN POWDER COATED YELLOW FINISH

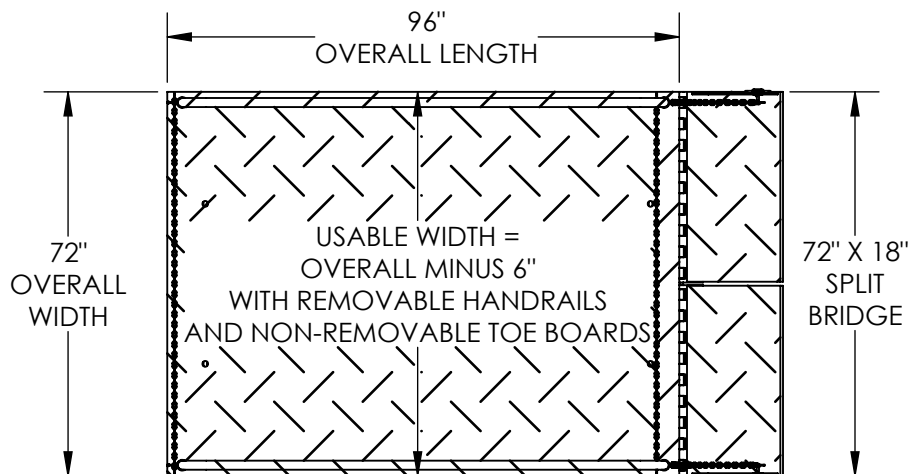

** STANDARD UNIT NOT INTENDED FOR SIDE CROSS LOAD **

-INSTALL TO MEET ALL APPLICABLE STATE & LOCAL CODES FOR YOUR AREA!

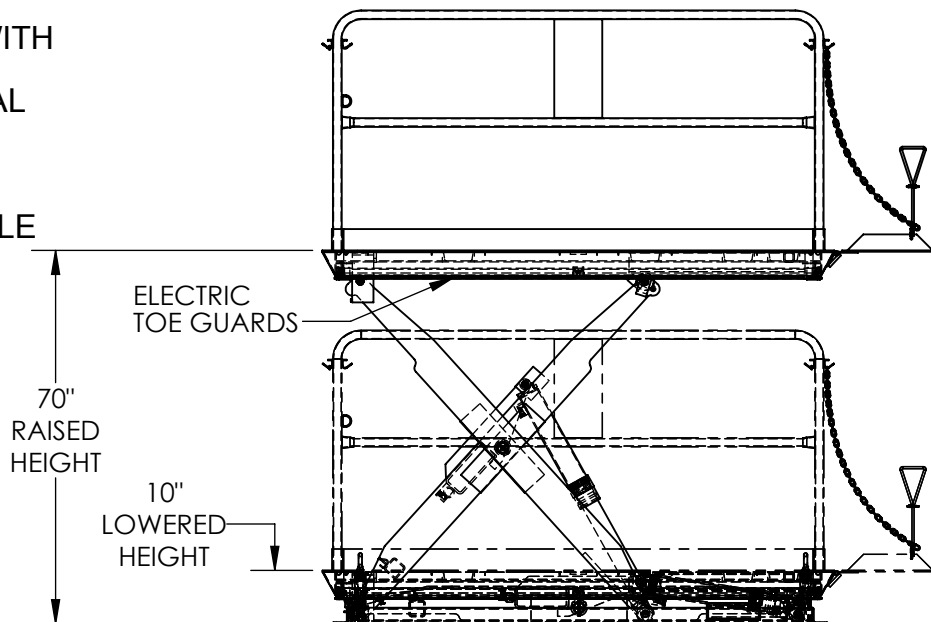

DIMENSION TOLERANCE ± 1/4"

SPECIAL FEATURES

NONE

HYDRAULIC UNIT OVERALL DIMENSIONS 14"W x 33"L x 31"H (COMES W/ 8FT HOSE)

A P P R O V A L

I, THE UNDERSIGNED, AGREE THAT THE PRODUCT AS REPRESENTED SATISFIES DESIGN AND DIMENSION REQUIREMENTS. I ALSO ACKNOWLEDGE MY DUTY TO CONFIRM PRODUCT AND INSTALLATION COMPLIANCE WITH ALL APPLICABLE FEDERAL, STATE AND LOCAL REGULATIONS AND STANDARDS.
UNITS REQUIRING APPROVAL DRAWINGS OR MODIFIED ARE NON-RETURNABLE
 As drawn As marked

Signed: _____ Date: _____

Printed Name: _____

LEAD TIME WILL START UPON RECEIPT OF SIGNED APPROVAL DRAWING

POWER	AC	DC (12V)	AIR/OIL
MOTOR VOLTAGE	115	208	230 460
DEDICATED CIRCUIT REQUIRED 60Hz			
MOTOR PHASE	SINGLE	THREE	
CONTROL	HAND	FOOT	



DISTRIBUTOR'S NAME:		P.O.#	
HOF EQUIPMENT COMPANY		X	
PH: 888.990.1150		W.O.#	
DRAWN BY: SJG		X	
DATE: 12/12/2018		SALES: X	
REFERENCE: X		SCALE: 1:36	
FILE NAME:		05-007-313	
QUOTED LEAD TIME: X		QUOTE #	
		X	

PRE MIUM TRUCK SCISSOR DOCK LIFT - WL-100-8-78

ANY ADDITIONS, DELETIONS, OR OMISSIONS MUST BE CORRECTED ON THIS DRAWING AS THIS DRAWING WILL BE CONSIDERED ALL INCLUSIVE
 ALL GRAPHICS PROVIDED ARE FOR REFERENCE ONLY. IF CERTAIN DIMENSIONS ARE CRITICAL PLEASE VERIFY THOSE DIMENSIONS WITH YOUR SALESPERSON

STANDARD FEATURES

MODEL NUMBER: WL-100-8-78
 UNIT TO BE MOUNTED: AT SURFACE
 OR IN PIT (CIRCLE ONE)
 CAPACITY (EVENLY DISTRIBUTED):
 8,000 LBS
 OVERALL PLATFORM SIZE: (84" X 96")
 RAISED HEIGHT 70" ± 2"
 LOWERED HEIGHT: 10"
 REMOVABLE HANDRAILS AND 4"NON-
 REMOVABLE TOE BOARDS 42" HT W/
 21" MIDRAIL
 TRUCK BRIDGE IS 72" W X 18" L AT
 ROLLER END W/ CHAINS & HANDLES
 FRAME SIZE IS: 62" W X 93" L
 SHIPPING WT APPROX: 3400 LBS ±
 6 1/2 HP POWER UNIT (SEE BOTTOM
 LEFT CORNER)
 W/ 8' OF HYDRAULIC HOSE
 -HAND-HELD CONTROL ON A
 4'-20' COIL CORD
 REFER TO THE UNIT'S ELECTRICAL
 DIAGRAM FOR
 ELECTRICAL SERVICE
 REQUIREMENTS
 -INSTALL TO MEET ALL APPLICABLE
 STATE & LOCAL
 CODES FOR YOUR AREA!
 5" BEVELED TOE GUARD
 ARCHITECTURAL REVIEW FOR
 CORRECTNESS OF PIT AND FOR
 COMPLIANCE TO LOCAL AND STATE
 CODES IS RECOMMENDED.

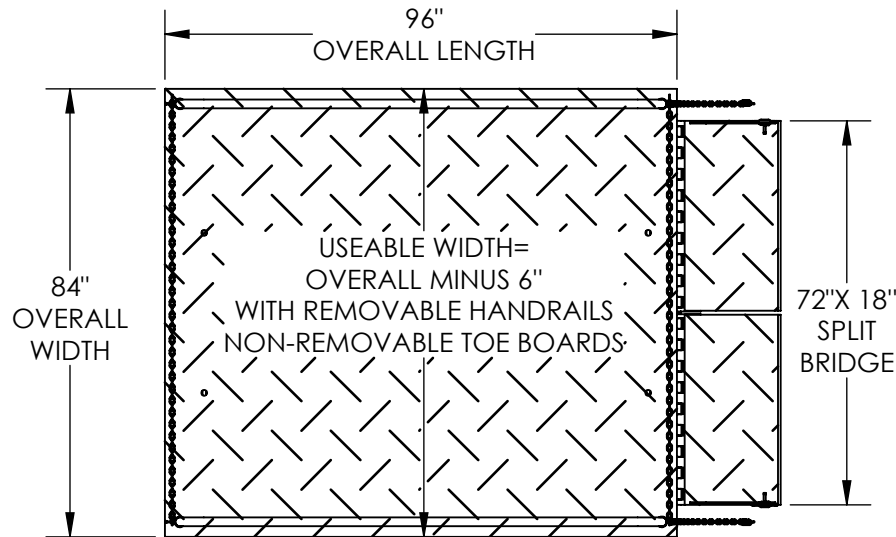

** STANDARD UNIT NOT INTENDED FOR SIDE CROSS LOAD **

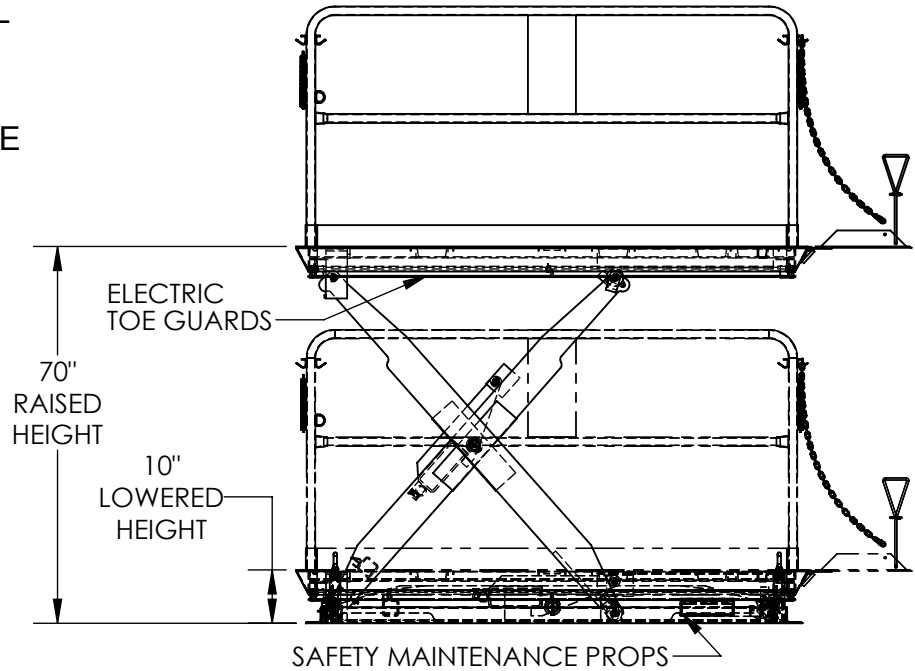

DIMENSION TOLERANCE ± 1/4"

SPECIAL FEATURES

NONE

FOR INTERNAL USE ONLY
 PROJECT SIGN OFF

SALES	
ENG.	
FAB.	
POWER	

APPROVAL

I, THE UNDERSIGNED, AGREE THAT THE PRODUCT AS REPRESENTED SATISFIES DESIGN AND DIMENSION REQUIREMENTS. I ALSO ACKNOWLEDGE MY DUTY TO CONFIRM PRODUCT AND INSTALLATION COMPLIANCE WITH ALL APPLICABLE FEDERAL, STATE AND LOCAL REGULATIONS AND STANDARDS.

ANY MODIFIED UNITS ARE NON-RETURNABLE

[] As drawn [] As marked

Signed: _____ Date: _____

Printed Name: _____

LEAD TIME WILL START UPON RECEIPT OF SIGNED APPROVAL DRAWING

HYDRAULIC UNIT
 OVERALL DIMENSIONS
 14"W x 33"L x 31"H
 (COMES W/ 8FT HOSE)

POWER	AC	DC (12V)	AIR/OIL
MOTOR VOLTAGE	115	208	230 460
DEDICATED CIRCUIT REQUIRED 60HZ			
MOTOR PHASE	SINGLE	THREE	
CONTROL	HAND	FOOT	

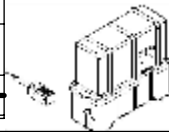

DISTRIBUTOR'S NAME:		P.O.#	
HOF EQUIPMENT COMPANY		X	
PH: 888.990.1150		W.O.#	
DRAWN BY: DLS		DATE: 5/1/2015	SALES: X
REFERENCE: X	SCALE: 1:36	FILE NAME:	
QUOTED LEAD TIME: X	QUOTE #	05-007-314	
	X		

PREMIUM TRUCK SCISSOR DOCK LIFT - WL-100-8-88

ANY ADDITIONS, DELETIONS, OR OMISSIONS MUST BE CORRECTED ON THIS DRAWING AS THIS DRAWING WILL BE CONSIDERED ALL INCLUSIVE

STANDARD FEATURES

MODEL NUMBER: **WL-100-8-88**
 UNIT TO BE MOUNTED: AT SURFACE
 OR IN PIT (CIRCLE ONE)
 CAPACITY (EVENLY DISTRIBUTED):
8,000 LBS
 OVERALL PLATFORM SIZE: **(96" X 96")**
 RAISED HEIGHT **70" ± 2"**
 LOWERED HEIGHT: **10"**
 REMOVABLE HANDRAILS AND 4"NON-
 REMOVABLE TOE BOARDS **45" HT W/
 21" MIDRAIL**
 TRUCK BRIDGE IS **72" W X 18" L** AT
 ROLLER END W/ CHAINS & HANDLES
 FRAME SIZE IS: **86 1/2" W X 93" L**
 SHIPPING WT APPROX: **3700 LBS ±**
6 1/2 HP POWER UNIT (SEE BOTTOM
LEFT CORNER)

W/ **8' OF HYDRAULIC HOSE**
-HAND-HELD CONTROL ON A
4'-20' COIL CORD

REFER TO THE UNIT'S ELECTRICAL
 DIAGRAM FOR

ELECTRICAL SERVICE
 REQUIREMENTS

-INSTALL TO MEET ALL APPLICABLE
 STATE & LOCAL

CODES FOR YOUR AREA!

5" BEVELED TOE GUARD

ARCHITECTURAL REVIEW FOR
 CORRECTNESS OF PIT AND FOR
 COMPLIANCE TO LOCAL AND STATE
 CODES IS RECOMMENDED.

DIMENSION TOLERANCE ± 1/4"

ALL GRAPHICS PROVIDED ARE FOR
 REFERENCE ONLY. IF CERTAIN DIMENSIONS
 ARE CRITICAL PLEASE VERIFY THOSE
 DIMENSIONS WITH YOUR SALESPERSON

SPECIAL FEATURES

NONE

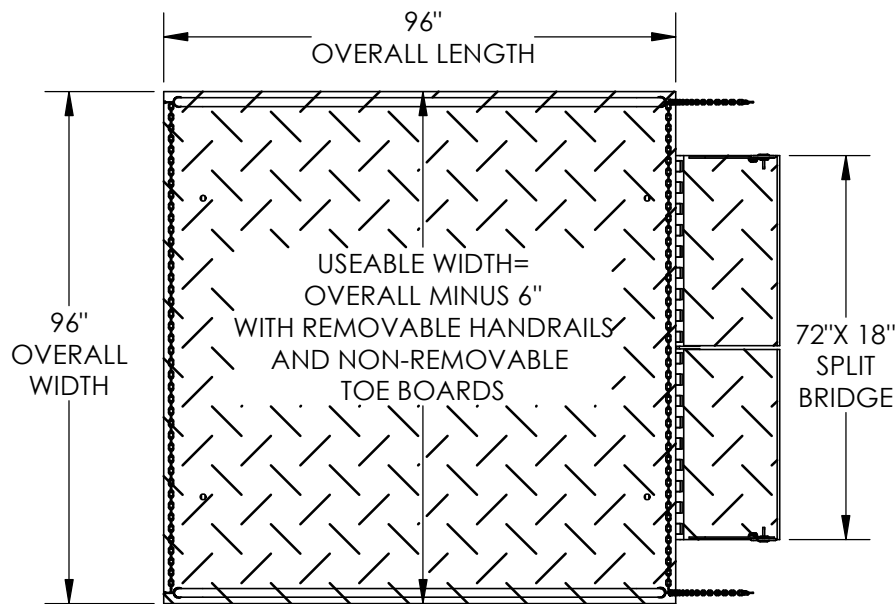

** STANDARD UNIT NOT INTENDED FOR SIDE CROSS LOAD **

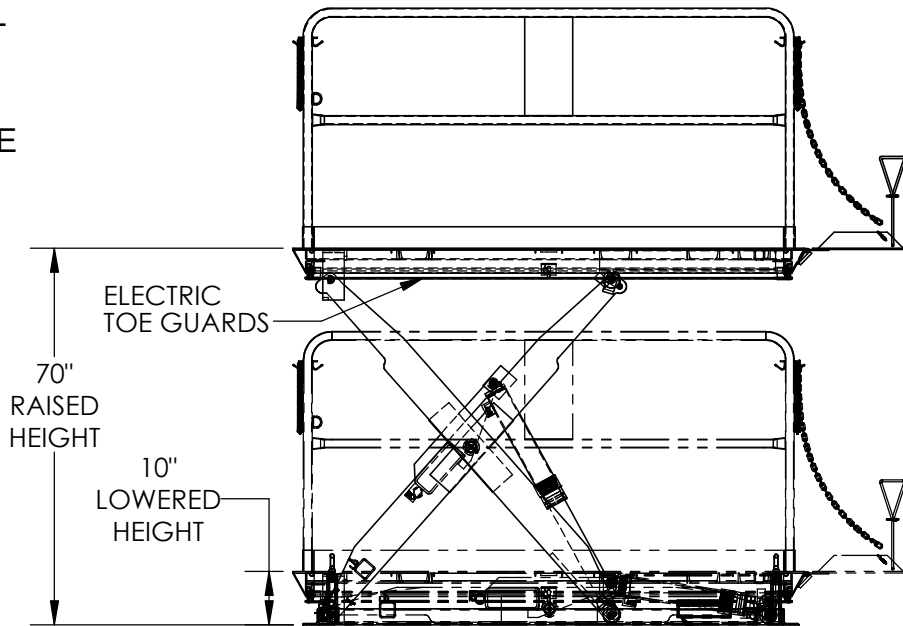

SAFETY MAINTENANCE PROPS

FOR INTERNAL USE ONLY
 PROJECT SIGN OFF

SALES	
ENG.	
FAB.	
POWER	

HYDRAULIC UNIT
 OVERALL DIMENSIONS
 14"W x 33"L x 31"H
 (COMES W/ 8FT HOSE)

APPROVAL

I, THE UNDERSIGNED, AGREE THAT THE PRODUCT AS REPRESENTED SATISFIES DESIGN AND DIMENSION REQUIREMENTS. I ALSO ACKNOWLEDGE MY DUTY TO CONFIRM PRODUCT AND INSTALLATION COMPLIANCE WITH ALL APPLICABLE FEDERAL, STATE AND LOCAL REGULATIONS AND STANDARDS.
ALL SPECIAL UNITS ARE NON-RETURNABLE
 As drawn As marked

Signed: _____ Date: _____

LEAD TIME WILL START UPON RECEIPT OF SIGNED APPROVAL DRAWING

POWER	AC	DC (12V)	AIR/OIL
MOTOR VOLTAGE	115	208	230 460
DEDICATED CIRCUIT REQUIRED 60HZ			
MOTOR PHASE	SINGLE	THREE	
CONTROL	HAND	FOOT	

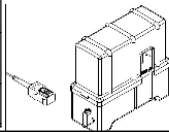

DISTRIBUTOR'S NAME: HOF EQUIPMENT COMPANY		P.O.# X
PH: 888.990.1150		W.O.# X
DRAWN BY: DLS	DATE: 12/11/2015	SALES: X
REFERENCE: X	SCALE: 1:36	FILE NAME:
QUOTED LEAD TIME: X	QUOTE # X	05-007-315

SCISSOR DOCK LIFT - WL-100-8-610

STANDARD FEATURES

- MODEL NUMBER: WL-100-8-610
- UNIT TO BE MOUNTED: AT SURFACE OR IN PIT (CIRCLE ONE)
- CAPACITY (EVENLY DISTRIBUTED): 8,000 LBS
- AXLE END LOAD CAPACITY IS: 6250 LBS
- AXLE SIDE LOAD CAPACITY IS: 5500 LBS
- OVERALL PLATFORM SIZE: 6' (72") x 10' (120")
- USABLE PLATFORM SIZE: SEE DIAGRAM
- RAISED HEIGHT: 70"
- LOWERED HT: 10"
- REMOVABLE HANDRAILS 45" HT W/ 21" MIDRAIL
AND 4" TOEBOARD, TOE BOARDS ARE: NON-REMOVABLE
- TRUCK BRIDGE IS 72" W x 18" L
W/ RUN OFF GUARDS, CHAINS & HANDLES

SHIPPING WT IS: 4812 LBS

- 6 1/2 HP POWER UNIT (SEE BOTTOM LEFT CORNER) W/ 8' OF HYDRAULIC HOSE
- 24 VAC HAND-HELD CONTROL ON A 4'-20' COIL CORD
- REFER TO THE UNIT'S ELECTRICAL DIAGRAM FOR ELEC. SERVICE REQUIREMENTS
- INSTALL TO MEET ALL APPLICABLE STATE & LOCAL CODES FOR YOUR AREA!
- 5" BEVELED TOE GUARD WITH ELECTRIC TOE GUARD
- THE ELECTRIC TOE GUARD AND UPPER LIMIT SWITCH CIRCUITS MUST BE COMPLETED BY INSTALLING AN 18/5 STD (OR EQUIV.) CABLE BETWEEN THE POWER UNIT AND THE JUNCTION BOX LOCATED IN THE LIFT'S FRAME
- UP SPEED AT FULL CAPACITY IS 4.3 SECONDS PER FOOT (@460 THREE PHASE)

FOR WARRANTY INFO SEE FORM WTY-91

ARCHITECTURAL REVIEW FOR CORRECTNESS OF PIT AND FOR COMPLIANCE TO LOCAL AND STATE CODES IS RECOMMENDED.

* Optional Features: (Available at additional cost)

- Dual speed hydraulic pump
- 2 HP single or three-phase power unit
- 3 HP single-phase power unit (1 1/2 GPM)
- 7 1/2 HP three-phase power unit (4.5 GPM)
- 10 HP three-phase power unit (6 GPM)
- Control lockout key switch
- Warning beeper during travel
- Warning strobe during travel
- Oil immersion heater w/ t'stat
- Power cord with twist-lock plug
- Longer hydraulic hose length
- 50,000 lbs. rollover capacity (lowered height + 2")
- Flush removable handrails and toeboard
- Additional split steel bridge
- Split aluminum truck bridge
- Four-sided accordion skirt (customer installs)
- Wheel and dolly jack kit (6,000# max. capacity)
- Automatic wheel chocks
- Stop signal sign
- Steel approach ramp (___" x ___")
- Cold galvanized deck and frame
- 115V single phase

** Any additions, deletions or omissions must be corrected on this drawing, as this drawing will be considered all inclusive. **

REMOTE POWER UNIT
Overall dimensions
13-1/4" W x 33" L x 31" H
(Cone w/ 8' hose)

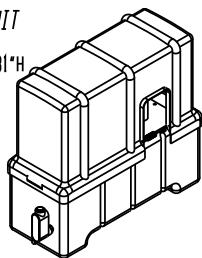
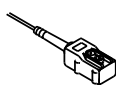

PLEASE CIRCLE SPECIFICATIONS:			
MOTOR VOLTAGE	208	230	(460)
DEDICATED CIRCUIT REQUIRED			
MOTOR PHASE	- (THREE)		

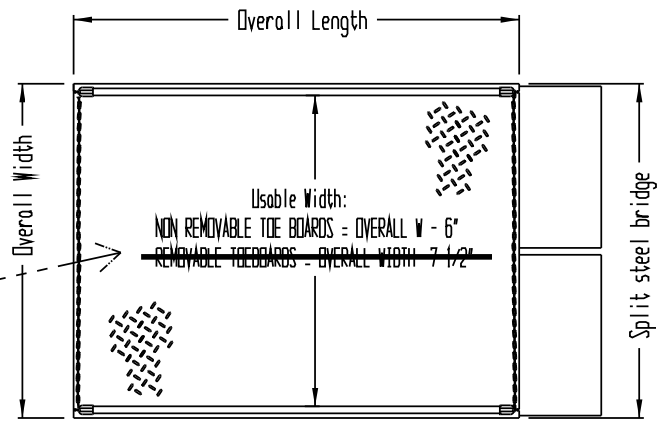

***STANDARD UNIT NOT INTENDED FOR SIDE/CROSS LOADING

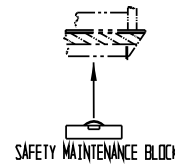
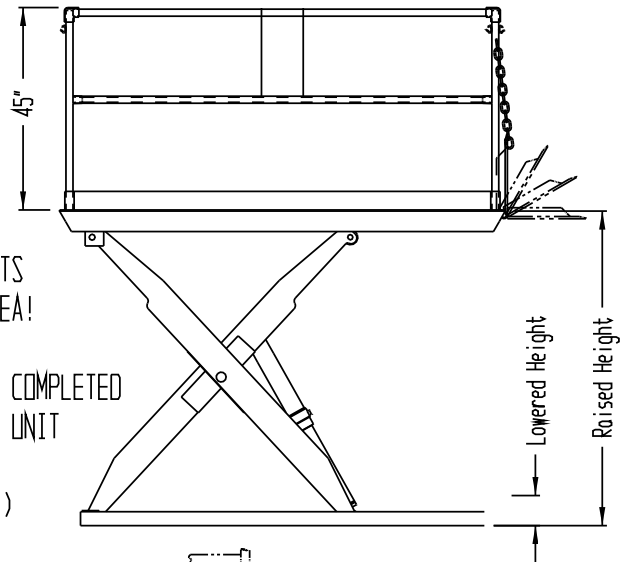

SAFETY MAINTENANCE BLOCK

PRODUCTION WILL START UPON RECEIPT OF SIGNED APPROVAL DRAWING

**SPECIAL UNITS ARE NON-RETURNABLE
*AVAILABLE AT ADDITIONAL COSTS

All graphics provided are for reference only.
If certain dimensions are critical please verify those dimensions with your salesperson

I, THE UNDERSIGNED, AGREE THAT THE PRODUCT AS REPRESENTED SATISFIES DESIGN & DIMENSION REQUIREMENTS. I ALSO ACKNOWLEDGE MY DUTY TO CONFIRM PRODUCT & INSTALLATION COMPLIANCE WITH ALL APPLICABLE FEDERAL, STATE AND LOCAL REGULATIONS & STANDARDS.

ALL SPECIAL UNITS ARE NON-RETURNABLE
[] As drawn [] As marked

Signed: _____ Date: _____
LEAD TIME WILL START UPON RECEIPT OF SIGNED APPROVAL DRAWING

DISTRIBUTOR'S NAME: HOF EQUIPMENT COMPANY PH: 888.990.1150		P.O.#: -
DRAWN BY: -	DATE: -	W.O.#: -
REFERENCE: -	SCALE: 1:40	SALES: -
QUOTED LEADTIME: -	QUOTE #: -	DRWG.#/FILE NAME: 05-007-012-002

SCISSOR DOCK LIFT - WL-100-8-710

STANDARD FEATURES

- MODEL NUMBER: WL-100-8-710
- UNIT TO BE MOUNTED: AT SURFACE OR IN PIT (CIRCLE ONE)
- CAPACITY (EVENLY DISTRIBUTED): 8,000 LBS
- AXLE END LOAD CAPACITY IS: 6,250 LBS
- AXLE SIDE LOAD CAPACITY IS: 5,250 LBS
- OVERALL PLATFORM SIZE: 7' (84") x 10' (120")
- USABLE PLATFORM SIZE: SEE DIAGRAM
- RAISED HEIGHT: 70"
- LOWERED HT: 10"
- REMOVABLE HANDRAILS 45" HT W/ 21" MIDRAIL
AND 4" TOEBOARD, TOE BOARDS ARE: NON-REMOVABLE
- TRUCK BRIDGE IS 72" W x 18" L
W/ RUN OFF GUARDS, CHAINS & HANDLES

SHIPPING WT IS: 4,918 LBS

- 6 1/2 HP POWER UNIT (SEE BOTTOM LEFT CORNER) W/ 8' OF HYDRAULIC HOSE
- 24 VAC HAND-HELD CONTROL ON A 4'-20' COIL CORD
- REFER TO THE UNIT'S ELECTRICAL DIAGRAM FOR ELEC. SERVICE REQUIREMENTS
- INSTALL TO MEET ALL APPLICABLE STATE & LOCAL CODES FOR YOUR AREA!
- 5" BEVELED TOE GUARD WITH ELECTRIC TOE GUARD
- THE ELECTRIC TOE GUARD AND UPPER LIMIT SWITCH CIRCUITS MUST BE COMPLETED BY INSTALLING AN 18/5 STD (OR EQUIV.) CABLE BETWEEN THE POWER UNIT AND THE JUNCTION BOX LOCATED IN THE LIFT'S FRAME
- UP SPEED AT FULL CAPACITY IS 4.3 SECONDS PER FOOT (@460 THREE PHASE)

FOR WARRANTY INFO SEE FORM WTY-91

ARCHITECTURAL REVIEW FOR CORRECTNESS OF PIT AND FOR COMPLIANCE TO LOCAL AND STATE CODES IS RECOMMENDED.

* Optional Features: (Available at additional cost)

- Dual speed hydraulic pump
- 2 HP single or three-phase power unit
- 3 HP single-phase power unit (1 1/2 GPM)
- 7 1/2 HP three-phase power unit (4.5 GPM)
- 10 HP three-phase power unit (6 GPM)
- Control lockout key switch
- Warning beeper during travel
- Warning strobe during travel
- Oil immersion heater w/ t'stat
- Power cord with twist-lock plug
- Longer hydraulic hose length
- 50,000 lbs. rollover capacity (lowered height + 2")
- Flush removable handrails and toeboard
- Additional split steel bridge
- Split aluminum truck bridge
- Four-sided accordion skirt (customer installs)
- Wheel and dolly jack kit (6,000# max. capacity)
- Automatic wheel chocks
- Stop signal sign
- Steel approach ramp (___" x ___")
- Cold galvanized deck and frame
- 115V single phase

** Any additions, deletions or omissions must be corrected on this drawing, as this drawing will be considered all inclusive. **

REMOTE POWER UNIT
Overall dimensions
13-1/4" W x 33" L x 31" H
(Cone w/ 8' hose)

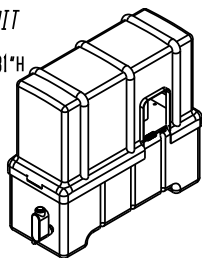
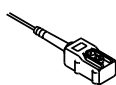

PLEASE CIRCLE SPECIFICATIONS:			
MOTOR VOLTAGE	208	230	460
DEDICATED CIRCUIT REQUIRED			
MOTOR PHASE	THREE		

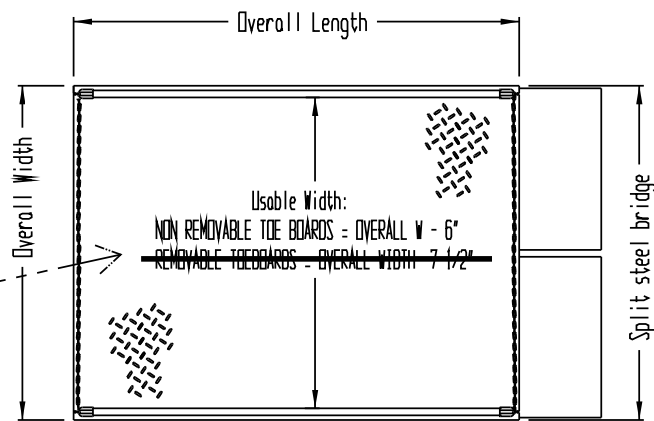

***STANDARD UNIT NOT INTENDED FOR SIDE/CROSS LOADING

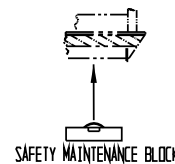
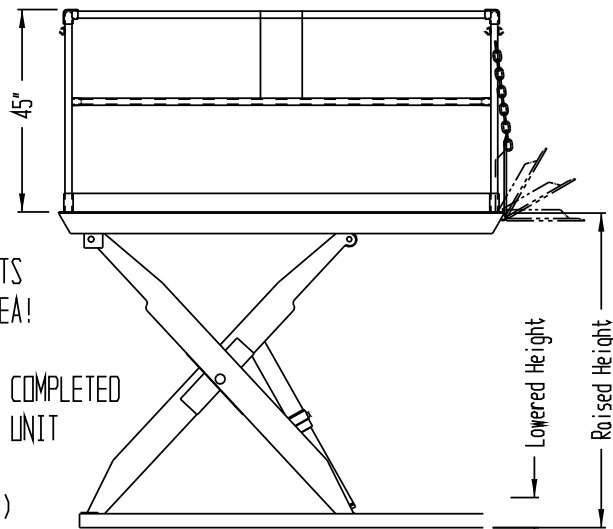

SAFETY MAINTENANCE BLOCK

PRODUCTION WILL START UPON RECEIPT OF SIGNED APPROVAL DRAWING

**SPECIAL UNITS ARE NON-RETURNABLE
*AVAILABLE AT ADDITIONAL COSTS

All graphics provided are for reference only.
If certain dimensions are critical please verify those dimensions with your salesperson

I, THE UNDERSIGNED, AGREE THAT THE PRODUCT AS REPRESENTED SATISFIES DESIGN & DIMENSION REQUIREMENTS. I ALSO ACKNOWLEDGE MY DUTY TO CONFIRM PRODUCT & INSTALLATION COMPLIANCE WITH ALL APPLICABLE FEDERAL, STATE AND LOCAL REGULATIONS & STANDARDS.

ALL SPECIAL UNITS ARE NON-RETURNABLE
[] As drawn [] As marked

Signed: _____ Date: _____
LEAD TIME WILL START UPON RECEIPT OF SIGNED APPROVAL DRAWING

DISTRIBUTOR'S NAME:		P.O.#:
HOF EQUIPMENT COMPANY		W.O.#:
PH: 888.990.1150		SALES:
DRAWN BY: _____	DATE: _____	SCALE: 1:40
REFERENCE: _____	DRWG.#/FILE NAME:	05-007-013-002
QUOTED LEADTIME: _____	QUOTE #:	

SCISSOR DOCK LIFT - WL-100-8-810

STANDARD FEATURES

- MODEL NUMBER: WL-100-8-810
- UNIT TO BE MOUNTED: AT SURFACE OR IN PIT (CIRCLE ONE)
- CAPACITY (EVENLY DISTRIBUTED): 8,000 LBS
- AXLE END LOAD CAPACITY IS: 6,250 LBS
- AXLE SIDE LOAD CAPACITY IS: 5,000 LBS
- OVERALL PLATFORM SIZE: 8' (96") x 10' (120")
- USABLE PLATFORM SIZE: SEE DIAGRAM
- RAISED HEIGHT: 70"
- LOWERED HT: 10"
- REMOVABLE HANDRAILS 45" HT W/ 21" MIDRAIL
AND 4" TOEBOARD, TOE BOARDS ARE: NON-REMOVABLE
- TRUCK BRIDGE IS 72" W x 18" L
W/ RUN OFF GUARDS, CHAINS & HANDLES

SHIPPING WT IS: 5,162 LBS

- 6 1/2 HP POWER UNIT (SEE BOTTOM LEFT CORNER) W/ 8' OF HYDRAULIC HOSE
- 24 VAC HAND-HELD CONTROL ON A 4'-20' COIL CORD
- REFER TO THE UNIT'S ELECTRICAL DIAGRAM FOR ELEC. SERVICE REQUIREMENTS
- INSTALL TO MEET ALL APPLICABLE STATE & LOCAL CODES FOR YOUR AREA!
- 5" BEVELED TOE GUARD WITH ELECTRIC TOE GUARD
- THE ELECTRIC TOE GUARD AND UPPER LIMIT SWITCH CIRCUITS MUST BE COMPLETED BY INSTALLING AN 18/5 STD (OR EQUIV.) CABLE BETWEEN THE POWER UNIT AND THE JUNCTION BOX LOCATED IN THE LIFT'S FRAME
- UP SPEED AT FULL CAPACITY IS 4.3 SECONDS PER FOOT (@460 THREE PHASE)

FOR WARRANTY INFO SEE FORM WTY-91

ARCHITECTURAL REVIEW FOR CORRECTNESS OF PIT AND FOR COMPLIANCE TO LOCAL AND STATE CODES IS RECOMMENDED.

* Optional Features: (Available at additional cost)

- Dual speed hydraulic pump
- 2 HP single or three-phase power unit
- 3 HP single-phase power unit (1 1/2 GPM)
- 7 1/2 HP three-phase power unit (4.5 GPM)
- 10 HP three-phase power unit (6 GPM)
- Control lockout key switch
- Warning beeper during travel
- Warning strobe during travel
- Oil immersion heater w/ t'stat
- Power cord with twist-lock plug
- Longer hydraulic hose length
- 50,000 lbs. rollover capacity (lowered height + 2")
- Flush removable handrails and toeboard
- Additional split steel bridge
- Split aluminum truck bridge
- Four-sided accordion skirt (customer installs)
- Wheel and dolly jack kit (6,000# max. capacity)
- Automatic wheel chocks
- Stop signal sign
- Steel approach ramp (___ " x ___ ")
- Cold galvanized deck and frame
- 115V single phase

** Any additions, deletions or omissions must be corrected on this drawing, as this drawing will be considered all inclusive. **

REMOTE POWER UNIT
Overall dimensions
13-1/4" W x 33" L x 31" H
(Cone w/ 8' hose)

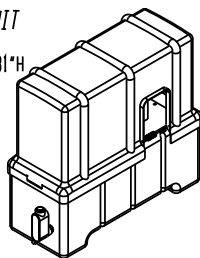
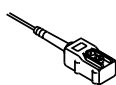

PLEASE CIRCLE SPECIFICATIONS:

MOTOR VOLTAGE	208	230	460
DEDICATED CIRCUIT REQUIRED			
MOTOR PHASE	THREE		

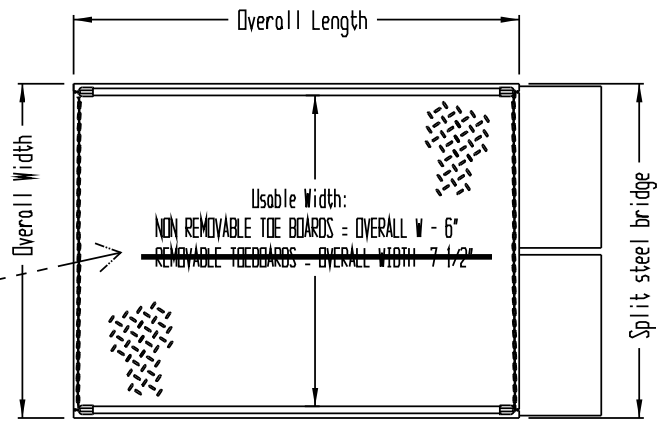

***STANDARD UNIT NOT INTENDED FOR SIDE/CROSS LOADING

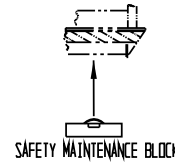
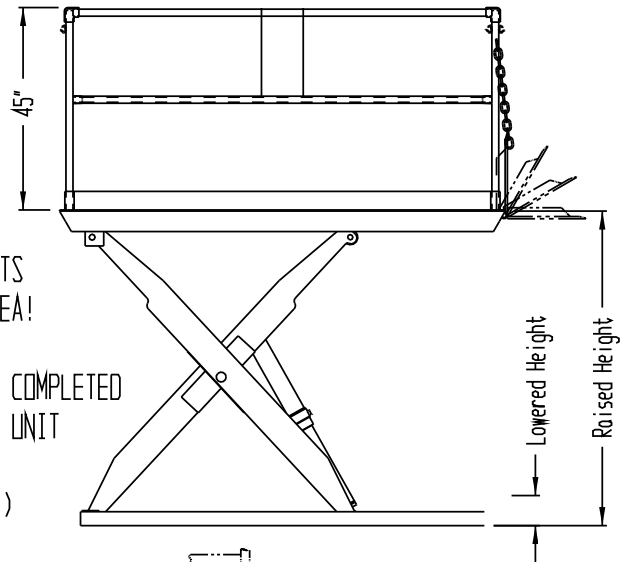

PRODUCTION WILL START UPON RECEIPT OF SIGNED APPROVAL DRAWING

**SPECIAL UNITS ARE NON-RETURNABLE
*AVAILABLE AT ADDITIONAL COSTS

All graphics provided are for reference only.
If certain dimensions are critical please verify those dimensions with your salesperson

I, THE UNDERSIGNED, AGREE THAT THE PRODUCT AS REPRESENTED SATISFIES DESIGN & DIMENSION REQUIREMENTS. I ALSO ACKNOWLEDGE MY DUTY TO CONFIRM PRODUCT & INSTALLATION COMPLIANCE WITH ALL APPLICABLE FEDERAL, STATE AND LOCAL REGULATIONS & STANDARDS.

ALL SPECIAL UNITS ARE NON-RETURNABLE
[] As drawn [] As marked

Signed: _____ Date: _____
LEAD TIME WILL START UPON RECEIPT OF SIGNED APPROVAL DRAWING

DISTRIBUTOR'S NAME: HOF EQUIPMENT COMPANY PH: 888.990.1150		P.O.#: -
DRAWN BY: -	DATE: -	W.O.#: -
REFERENCE: -	SCALE: 1:40	SALES: -
QUOTED LEADTIME: -	QUOTE #: -	DRWG.#/FILE NAME: 05-007-014-002